

Package View

Surface Mount package packed per EIA/JEDEC Standard RS-481, IEC60286-3

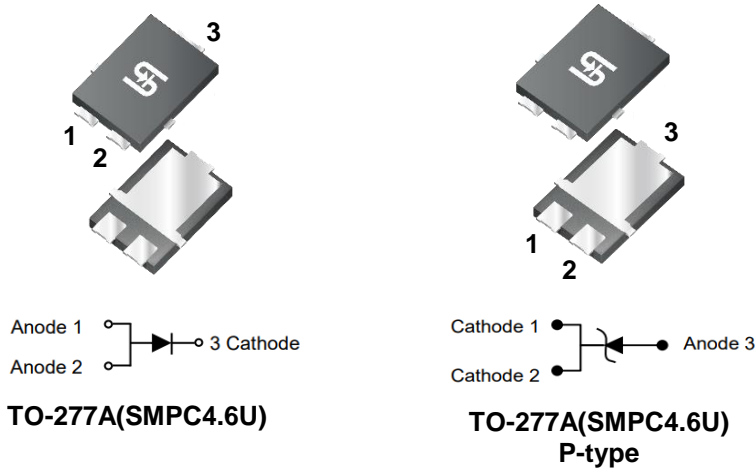

Packing Quantity

Packing Type	Packing Code	Packaging Description	Reel (pc)	Inner Box (pc)	Carton (pc)	Carton Size (mm)
Reel	--	12 mm Tape, 13" Diameter Plastic Reel	6,000	12,000	60,000	360x356x230

Component Orientation

Device Orientation and Direction of Feed

Unidirectional : Cathode Toward Sprocket Hole.

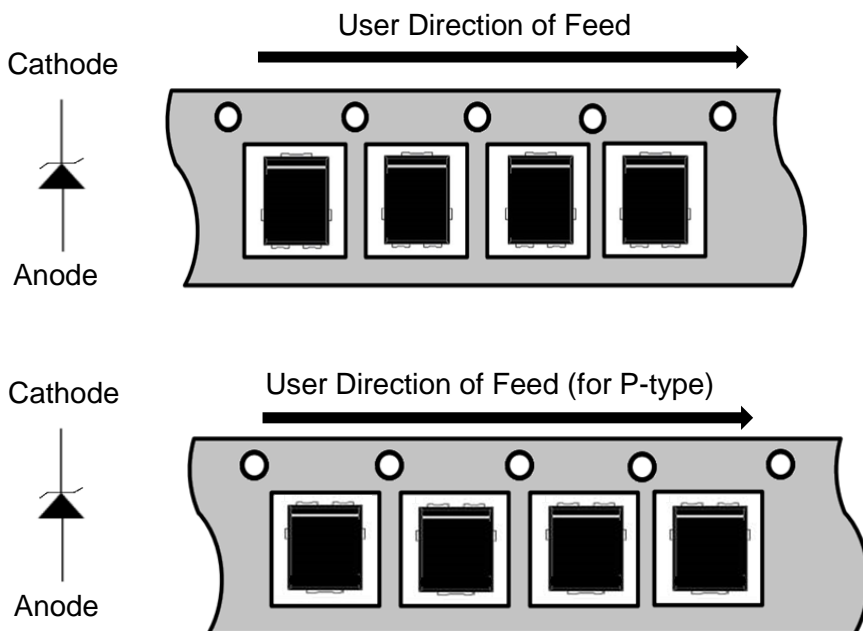

Component Lateral Movement

Maximum lateral movement for punched and embossed carrier
12 mm Tape

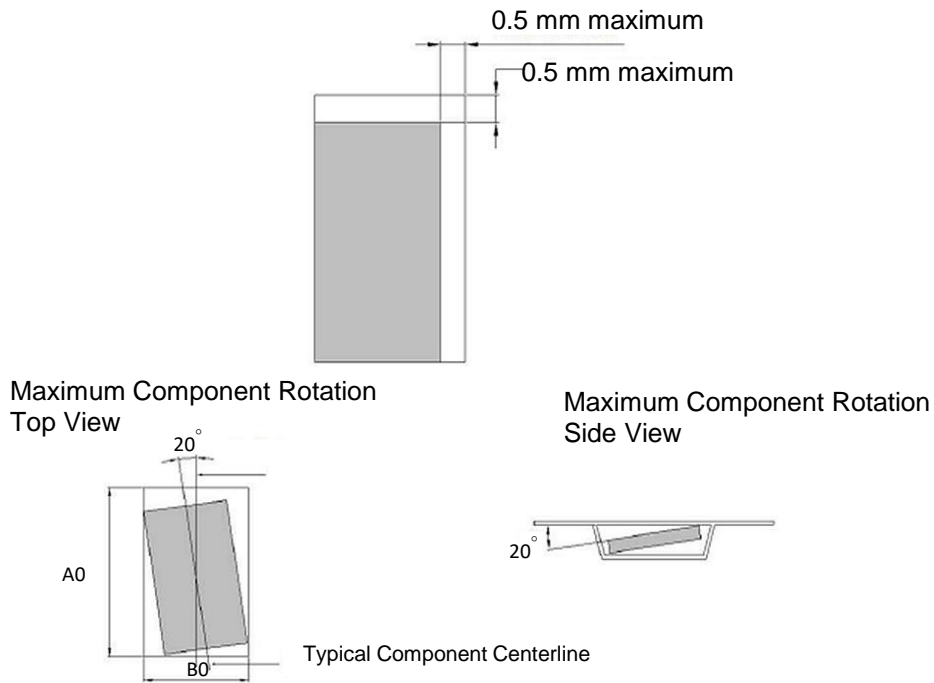

Tape leader & trailer

- Unfilled leader and trailer pockets are sealed
- Leaders and trailers are taped to tape and hub, respectively, with masking tape
- All materials are static-dissipative

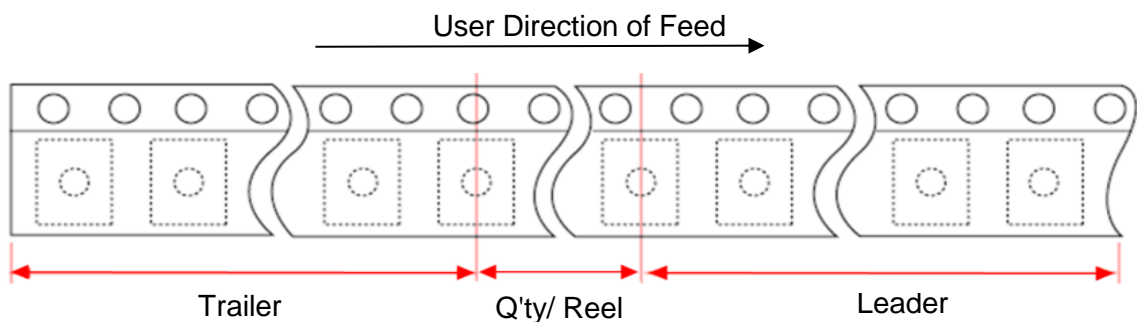

Trailer	Q'ty/Reel	Leader
Min 160 mm	6,000	Min 400 mm

Embossed Carrier Tape Specification

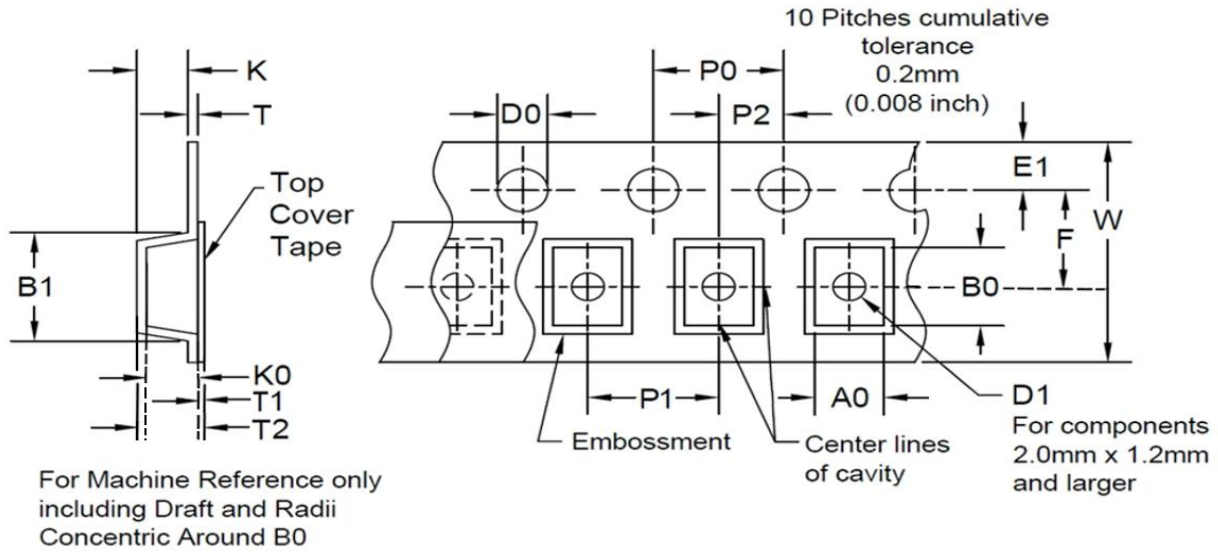

Note 1: B1 is for tape feeder reference only, including draft concentric about Bo.

Note 2 : A0,B0,K0 are determined by component size. The clearance between the component and the cavity must be within 0.05mm(.002")min. to 0.65mm(.025")max. for 12mm tape, 0.05mm(.002")min to 0.90mm(.035")max. for 16mm tape. In addition, the components cannot rotate more than 20° within the determined cavity.

Note3: Surface Resistance $10^4 \sim 10^8 \Omega$

ALL DIMENSION IN MILLIMETERS(Unit : mm)

Dim	Tape size	D0	E1	P0	P2	T	Ao	Bo	Ko
Spec	12 mm	1.5 +0.10	1.75 ±0.10	4 ±0.10	2 ±0.05	0.25 ±0.02	4.96 ±0.10	6.93 ±0.10	1.27 ±0.10

Dim	Tape size	B1	D1	F	W	P1	K	T1	T2
Spec	12 mm	--	1.5 +0.25	5.5 ±0.05	12 +0.3, -0.10	8 ±0.10	--	--	--

Reel Dimension

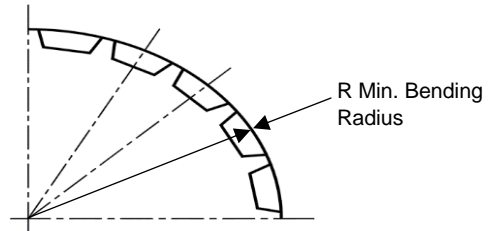
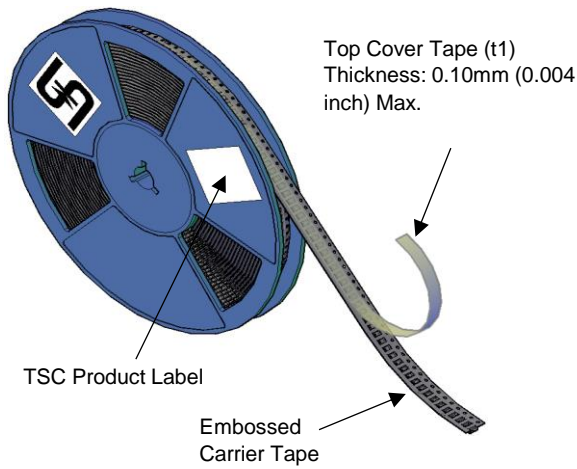

Tape with components shall pass around bending radius without damage, for reels with hub diameters. approaching minimum dimension.

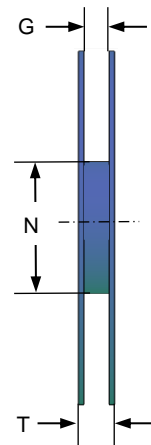
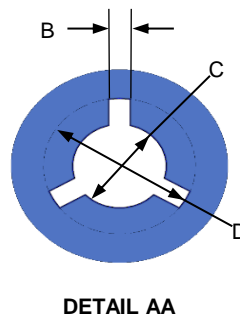
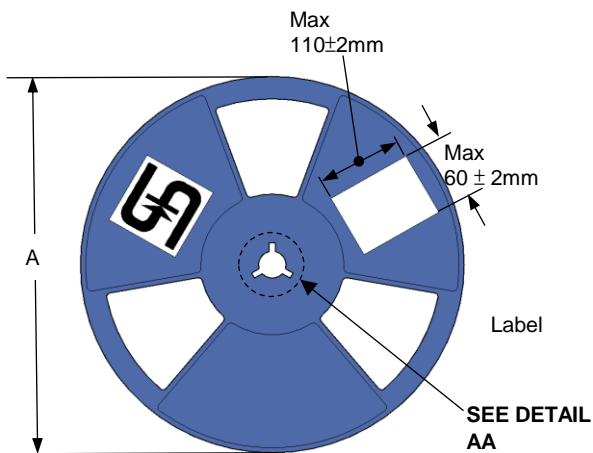

ALL DIMENSION IN MILLIMETERS (Unit : mm)

Reel Size	Tape size	A	B	C	D	N	G	T
13"	12 mm	330 ±0.5	2.5 ±0.5	13.5 ±0.5	-	99.5 ±0.5	12.6 ±0.5	17.2 ±0.5

Note1: Surface Resistance $10^6 \sim 10^{11} \Omega$